

Waterproof 3030 LED slide light Bar for light box

GMFT1000-18W3030



◆ Product Advantages

- High color consistency .
- Use Al Heat-sink to ensure heat dissipation.
- Silicone potting, IP Level: IP65.
- 20*45°Beam Angle, High Efficiency, High Uniformity Lens
- Shutter-type installation, easy operation
- The max. length could not be over 2 meters when serial connection. If length is over 2 meters, you could see voltage drop which can cause hazardous overload and damage the bar

◆ Product features:

- Input Voltage: DC12V/DC24V
- Efficiency: 110lm/ W
- Luminous: 2970 lm / pc
- lifetime: > 30000 hours

◆ Applications:

Best for 15-30cm depth double-sided light box or 8-20 cm depth single-sided light box at airports, metros,banks, buildings and shopping malls, etc.



◆ Installation:

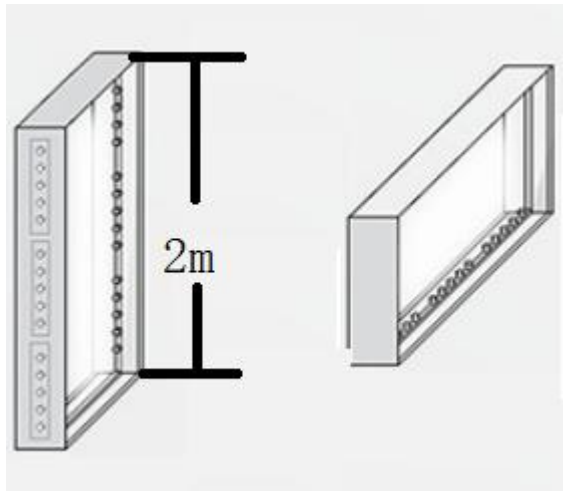

◆ Parameters:

Part No.	Led Type	Color	LED No.	Working Voltage	Power	SIZE
GMBT1000-18W3030	3535	3000/4000/6500k	18	DC12V/DC24V	27W	1000*27*20MM

◆ Connection:

LED strip+ LED power supply

DC24V/DC12V

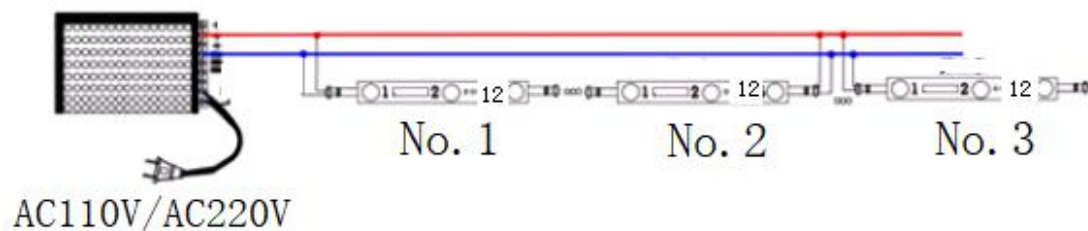

◆ **Package information:**

The carton size: 1080*290*250;150 PCS/BOX.



◆ **Installation Guide:**

- The strip itself and all its components could not be mechanically stressed.
- Assembly must not damage or destroy conducting paths on the circuit board. The installation must be carried out by qualified personnel;
- Please check correct electrical polarity before connection. Wrong polarity may destroy the strip;
- The max. length could not be over 2 meters when serial connection. If length is over 2 meters, you could see voltage drop which can cause hazardous overload and damage the strip
- Strips must be installed in a suitable environment. It is the user's responsibility to provide suitable protection against corrosive agents such as moisture and condensation and other harmful elements
- Before any application it is advisable to clean the surface where the strip will be glued; must be glued to a thermal-conductive surface, preferably aluminum.